

HARVIL SOLID WOOD SLATE POOL TABLE ASSEMBLY INSTRUCTIONS

HARVIL®



NGD2630/NGD2645

THANK YOU!

HARVIL®

Thank you for your purchase of this Harvil product.

We work around the clock and around the globe to ensure that Harvil products maintain the highest possible quality. However, in the rare instance that your product is defective or missing parts, contact your retailer to submit parts requests or warranty claims. Please read the warranty information at the back of these assembly instructions for further details.

IMPORTANT! PLEASE READ THESE ASSEMBLY INSTRUCTIONS IN ENTIRETY BEFORE ASSEMBLING YOUR PRODUCT.

ATTENTION!

This pool table should **ONLY** be assembled and set up by a professional billiards installer. Damage due to improper installation is **NOT** covered by the warranty.

This manual details only the assembly of the cabinet and hardware. It does **NOT** include instructions for leveling the slate or attaching the felt.

Please note that some figures or drawings may not look exactly like your product.

This slate pool table is very **HEAVY**. Before assembly, ensure that the intended location can handle the sustained weight of the table. Harvil is not responsible for property or structural damage due to the placement of this table.

This pool table is intended for **INDOOR** use only.







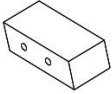
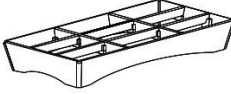

Do **NOT** sit, climb or stand on this pool table.

This pool table should **ONLY** be moved by a professional to prevent damage to the table and slate.





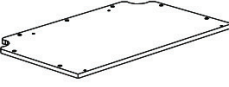

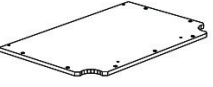



PARTS IDENTIFIER (NOT TO SCALE)

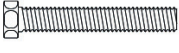

PARTS:

<p>#1</p>  <p>LEG 4 pcs</p>	<p>#2</p>  <p>WOOD BLOCK 8 pcs</p>	<p>#3</p>  <p>CABINET 1 pc</p>	<p>#4</p>  <p>TOP LEFT RAIL 2 pcs</p>	<p>#5</p>  <p>TOP RIGHT RAIL 2 pcs</p>
<p>#6</p>  <p>TOP END RAIL 2 pcs</p>	<p>#7</p>  <p>CORNER POCKET 4 pcs</p>	<p>#8</p>  <p>SIDE POCKET 2 pcs</p>	<p>#9</p>  <p>SLATE (LEFT) 1 pc</p>	<p>#10</p>  <p>SLATE (CENTER) 1 pc</p>
<p>#11</p>  <p>SLATE (RIGHT) 1 pc</p>				

HARDWARE:

<p>#H1</p>  <p>HEX BOLT 3/8" X 2-1/2" 4 pcs</p>	<p>#H2</p>  <p>FLAT WASHER 3/8"ID X 1-1/4"OD 4 pcs</p>	<p>#H3</p>  <p>FLAT HEAD SCREW #8 X 1" 8 pcs</p>	<p>#H4</p>  <p>HEX BOLT 5/16" X 2" 16 pcs</p>	<p>#H5</p>  <p>FLAT WASHER 5/16"ID X 7/8"OD 16 pcs</p>
<p>#H6</p>  <p>HEX BOLT 3/8" X 2-1/2" 18 pcs</p>	<p>#H7</p>  <p>DOME WASHER 3/8"ID X 1-1/4"OD 18 pcs</p>	<p>#H8</p>  <p>FLAT HEAD SCREW #10 X 2-1/4" 12 pcs</p>	<p>#H9</p>  <p>HEX BOLT 5/16" X 1" 12 pcs</p>	<p>#H10</p>  <p>FLAT WASHER 5/16"ID X 7/8"OD 12 pcs</p>
<p>#H11</p>  <p>FLAT HEAD SCREW #6 X 7/16" 30 pcs</p>				

1. Attach one LEG #1 to each corner of CABINET #3 as shown with HEX BOLT #H1 and FLAT WASHER #H2 and two FLAT HEAD SCREWS #H3.

2. Attach WOOD BLOCKS #2 to outside edge of CABINET #3 as shown with HEX BOLT #H4 and FLAT WASHER #H5.

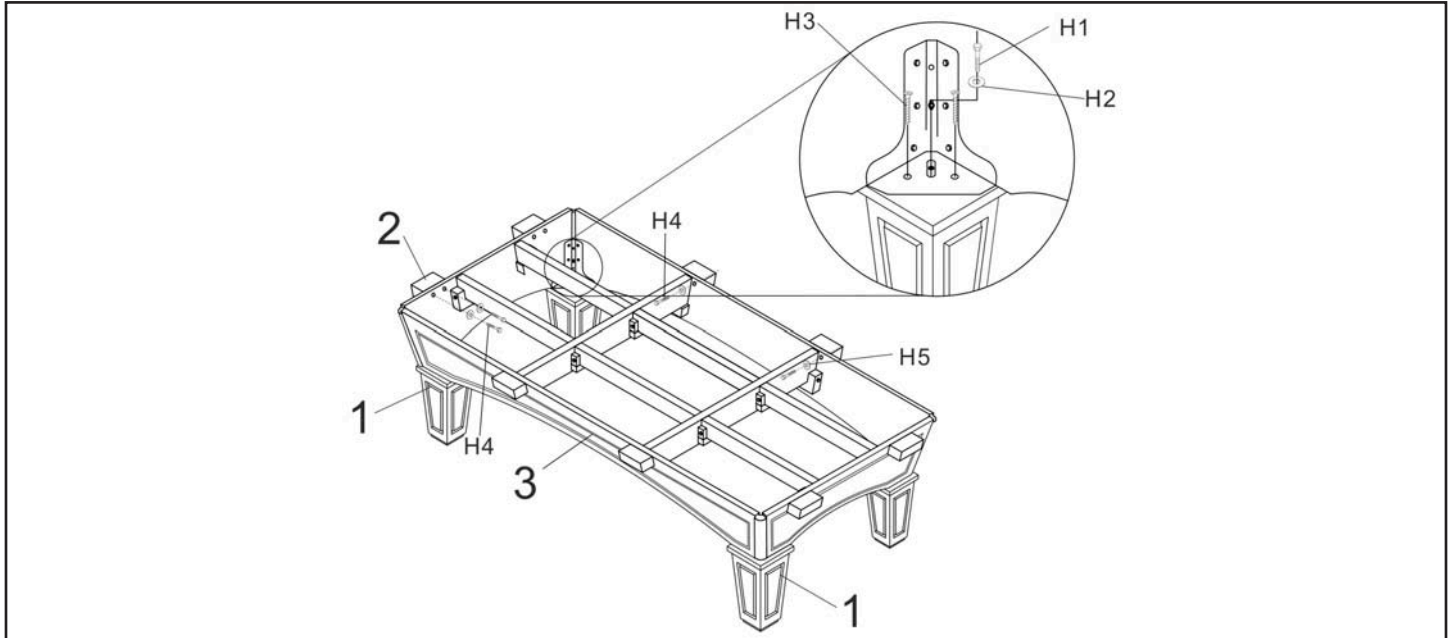

3. Lay SLATE #9, #10 and #11 on CABINET and secure to WOOD BLOCKS as shown with FLAT HEAD SCREW #H8.

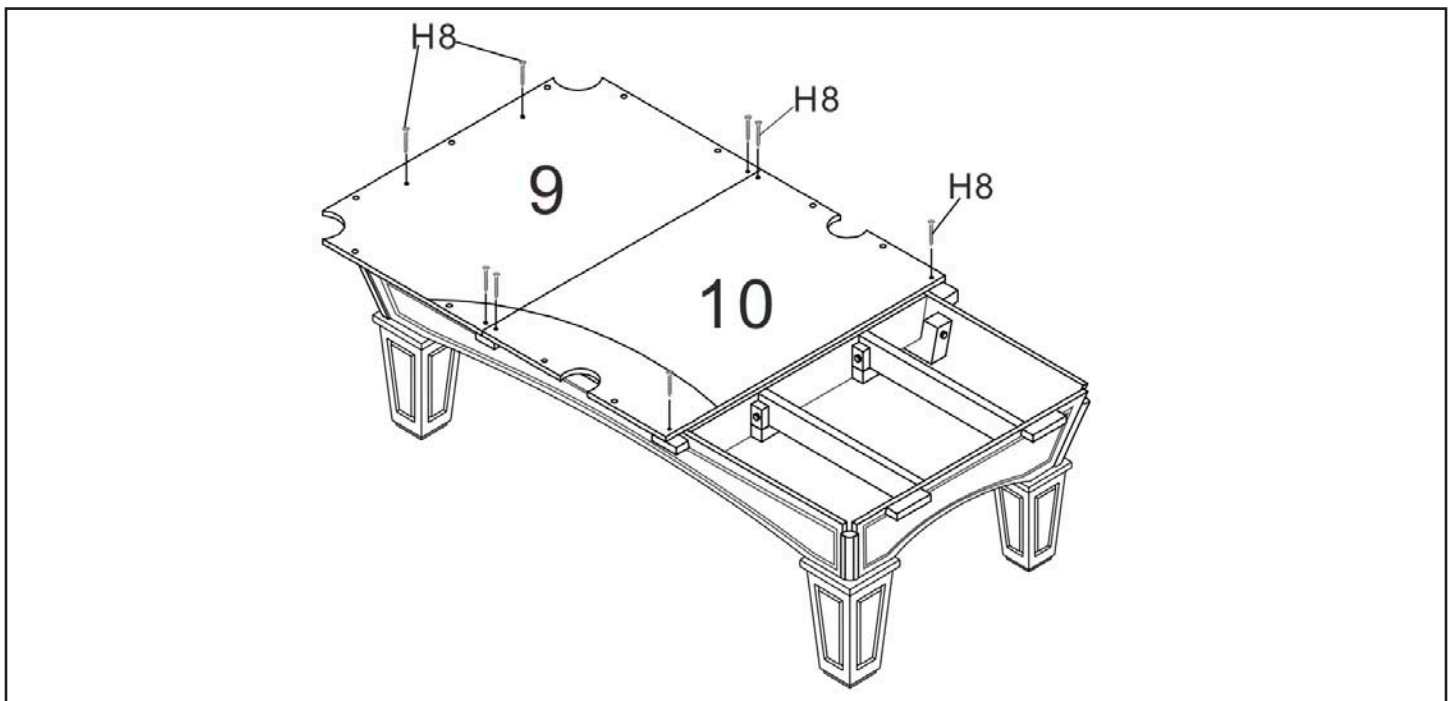

4. Attach one CORNER POCKET #7 to one TOP LEFT RAIL #4 and one TOP END RAIL #6 with HEX BOLT #H9 and FLAT WASHER #H10. Attach one CORNER POCKET #7 to TOP RIGHT RAIL #5 and opposite end of assembled TOP END RAIL #6 with HEX BOLT #H9 and FLAT WASHER #H10. Repeat assembly with remaining CORNER POCKETS and RAILS.

5. Attach assembled RAILS to SIDE POCKETS #8 with HEX BOLT #H9 and FLAT WASHER #H10.

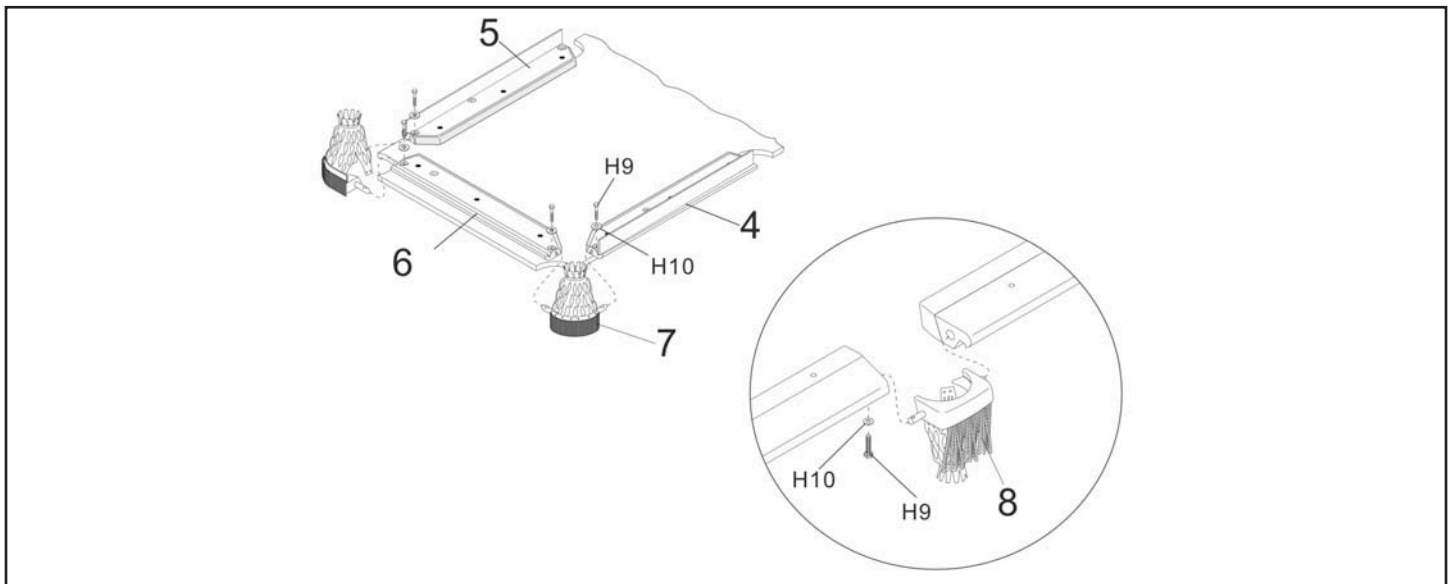

6. Carefully lay assembled RAILS on top of SLATE and secure with HEX BOLT #H6 and DOME WASHER #H7.

7. Secure POCKETS with FLAT HEAD SCREW #H11.

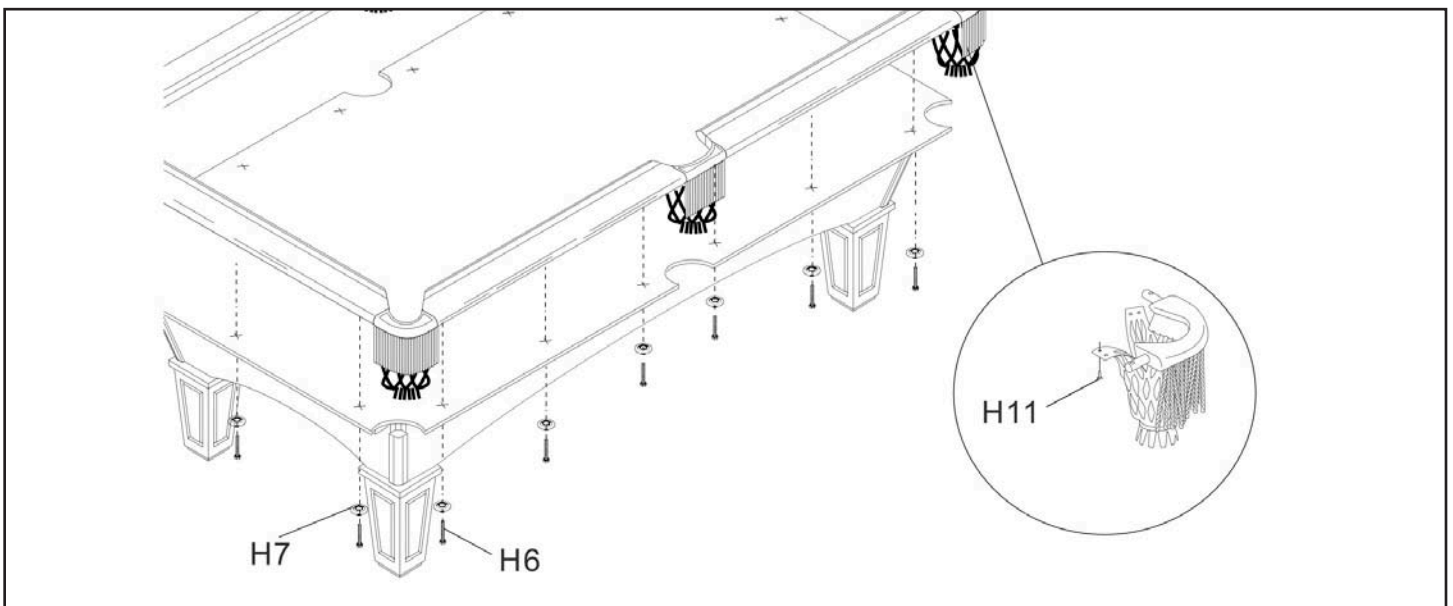



This Harvil product is warranted to the original purchaser to be free from defects in material or workmanship for a period of one year from the date of the original retail purchase.

This warranty does not cover defects or damage due to improper installation, alteration, accident or any other event beyond the control of the manufacturer. Defects or damage resulting from misuse, abuse or negligence will void this warranty. This warranty does not cover scratching or damage that may result from normal usage.

This product is not intended for institutional or commercial use; Harvil does not assume any liability for such use. Institutional or commercial use will void this warranty.

This warranty is nontransferable and is expressly limited to the repair or replacement of the defective product. During the warranty period, Harvil shall repair or replace defective parts at no cost to the purchaser. Shipping charges and insurance are not covered and are the responsibility of the purchaser. Labor charges and related expenses for removal, installation or replacement of the product or components are not covered under this warranty.

Harvil reserves the right to make substitutions to warranty claims if parts are unavailable or obsolete.

Harvil shall not be liable for loss of use of the product or other consequential or incidental costs, expenses or damages incurred by the consumer of any other use. The user assumes all risk of injury resulting from the use of this product.

This warranty is expressly in lieu of all other warranties, expressed or implied, including warranties of merchantability or fitness for use to the extent permitted by Federal or state law. Neither Harvil nor any of its representatives assumes any other liability in connection with this product.

All warranty claims must be made through the retailer where the product was originally purchased. A purchase receipt or other proof of date of purchase will be required to process all warranty claims. The model number and part numbers found within the assembly instructions will be required when submitting any parts requests or warranty claims.

For further warranty information or inquiries, please call 800-759-0977