

# MLS STRIKER SOCCER TABLE ASSEMBLY INSTRUCTIONS



NGD1031

THANK YOU!















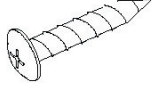
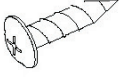
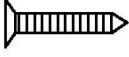

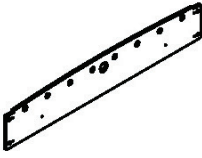
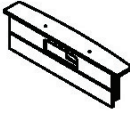
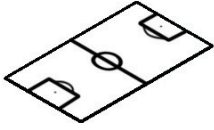

Thank you for your purchase of this Harvil product.

We work around the clock and around the globe to ensure that Harvil products maintain the highest possible quality. However, in the rare instance that your product is defective or missing parts, contact your retailer to submit parts requests or warranty claims. Please read the warranty information at the back of these assembly instructions for further details.

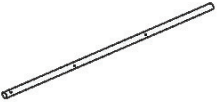
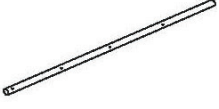
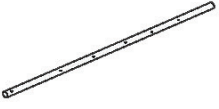
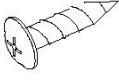
**IMPORTANT! PLEASE READ THESE ASSEMBLY INSTRUCTIONS IN ENTIRETY BEFORE ASSEMBLING YOUR PRODUCT.**

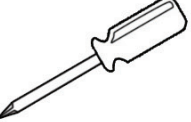

# PARTS IDENTIFIER (NOT TO SCALE)

<p>#1</p>  <p><b>BOLT</b> 16 pcs</p>	<p>#2</p>  <p><b>FLAT WASHER</b> 16 pcs</p>	<p>#3</p>  <p><b>1-1/2" SCREW</b> 4 pcs</p>	<p>#4</p>  <p><b>1/2" SCREW</b> 12 pcs</p>	<p>#5</p>  <p><b>1-1/2" FLAT SCREW</b> 12 pcs</p>
<p>#6</p>  <p><b>HEX WRENCH</b> 1 pc</p>	<p>#7</p>  <p><b>SIDE PANEL</b> 2 pcs</p>	<p>#8</p>  <p><b>END PANEL</b> 2 pcs</p>	<p>#9</p>  <p><b>PLAYFIELD</b> 1 pc</p>	<p>#10</p>  <p><b>LEFT LEG</b> 2 pcs</p>
<p>#11</p>  <p><b>RIGHT LEG</b> 2 pcs</p>	<p>#12</p>  <p><b>LEG PANEL</b> 2 pcs</p>	<p>#13</p>  <p><b>HAND GRIP</b> 8 pcs</p>	<p>#14</p>  <p><b>BLUE PLAYER</b> 13 pcs</p>	<p>#15</p>  <p><b>GREEN PLAYER</b> 13 pcs</p>
<p>#16</p>  <p><b>2 PLAYER ROD</b> 2 pcs</p>	<p>#17</p>  <p><b>3 PLAYER ROD</b> 4 pcs</p>	<p>#18</p>  <p><b>5 PLAYER ROD</b> 2 pcs</p>	<p>#19</p>  <p><b>3/4" SCREW</b> 26 pcs</p>	<p>#20</p>  <p><b>FOAM BUMPER</b> 16 pcs</p>
<p>#21</p>  <p><b>PLASTIC ROD WASHER</b> 16 pcs</p>	<p>#22</p>  <p><b>ROD END CAP</b> 8 pcs</p>	<p>#23</p>  <p><b>PLAYFIELD SUPPORT BRACE</b> 2 pcs</p>	<p>#24</p>  <p><b>MANUAL SCORER</b> 2 pcs</p>	<p>#25</p>  <p><b>SOCCER BALL</b> 2 pcs</p>
<p>ADDITIONAL EQUIPMENT REQUIRED:</p>  <p><b>PHILLIPS HEAD SCREWDRIVER</b></p>				



1. Find a clean, level surface to begin the assembly of your game table. The table will be partially assembled upside down and then turned over onto its legs. This is a heavy game and turning it over will require at least two strong adults.
2. Remove all of the contents from box and verify that you have all of the parts shown on the Parts Identifier before you begin assembly. **Note: Some parts may be pre-installed or pre-assembled.**
3. Some figures or drawings may not look exactly like your product. Please read and understand the text before beginning each assembly step.
4. When installing parts that have more than one screw or bolt, hand tighten all screws or bolts in place before finishing tightening with screwdriver or hex wrench.
5. Electric screwdrivers may be helpful during assembly; however, please set a low torque and use extreme caution because screws may be stripped or overtightened if the electric screwdriver's torque is set too high.

### **WARNINGS!**

READ AND FOLLOW ALL ASSEMBLY, OPERATION AND SAFETY INSTRUCTIONS CAREFULLY.

CHOKER HAZARD - THIS TABLE CONTAINS SMALL BALLS AND PARTS - NOT  
SUITABLE FOR CHILDREN UNDER 3 YEARS OF AGE.



# ASSEMBLY INSTRUCTIONS

1. Insert pre-assembled BLUE PLAYER RODS and GREEN PLAYER RODS into one SIDE PANEL #7 as shown below. *Note: Although this table is assembled upside down, players are shown upright for clarity. Each team should face the opposite goal when table is turned over. Ensure that FOAM BUMPERS and PLASTIC ROD WASHERS are in place before inserting rods.*

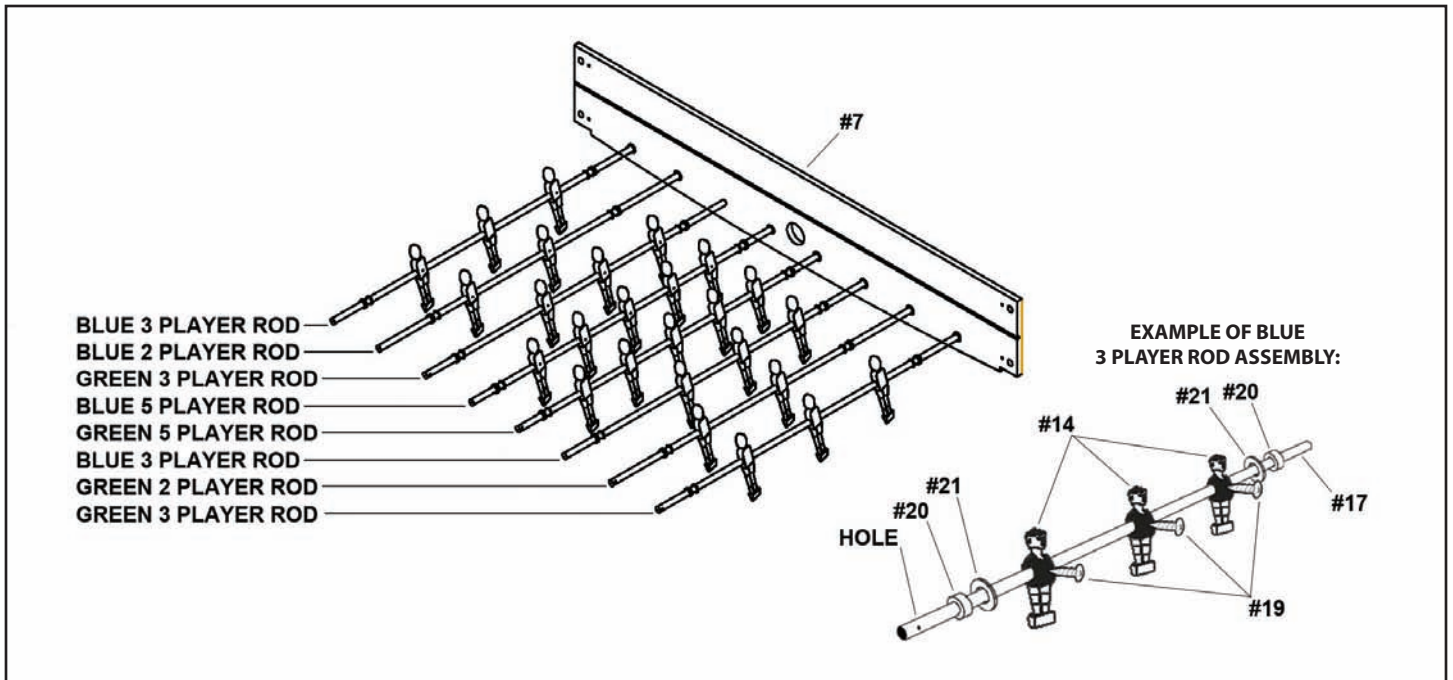

2. Insert PLAYER RODS into remaining SIDE PANEL #7.

3. Attach one END PANEL #8 to one end of the table with 1-1/2" FLAT SCREW #5.

4. Slide PLAYFIELD #9 with field markings facing down into the SIDE PANEL grooves.

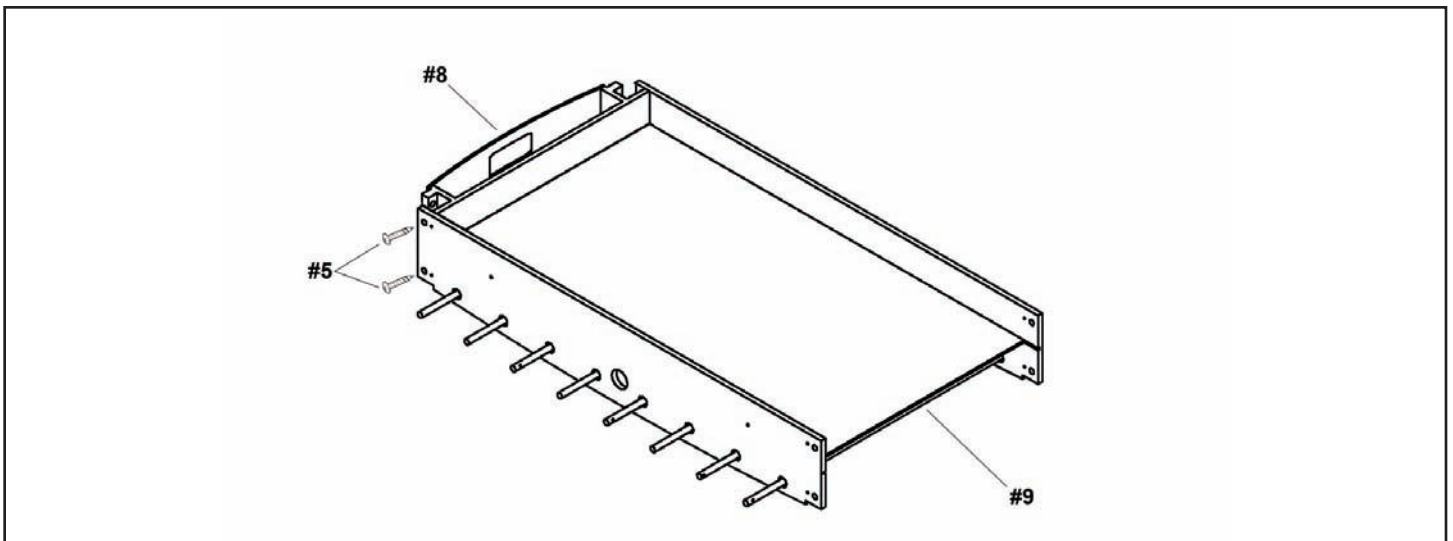



## ASSEMBLY INSTRUCTIONS (CONT.)

5. Attach remaining END PANEL #8 to the opposite end of the table with 1-1/2" FLAT SCREW #5.

6. Attach each PLAYFIELD SUPPORT BRACE #23 across the underside of the PLAYFIELD by fastening to the SIDE PANELS with 1-1/2" SCREW #3.

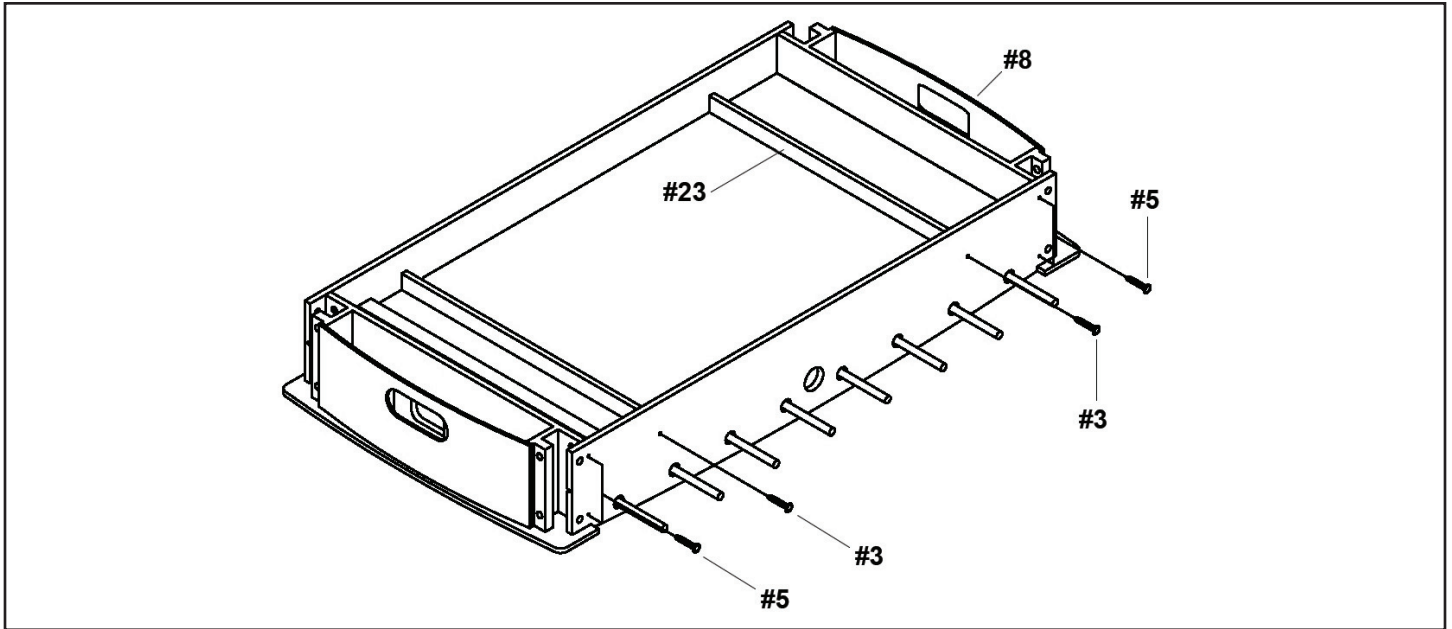

7. Attach LEFT LEGS #10 and RIGHT LEGS #11 to the corners of the table as shown below using BOLT #1 and FLAT WASHER #2.

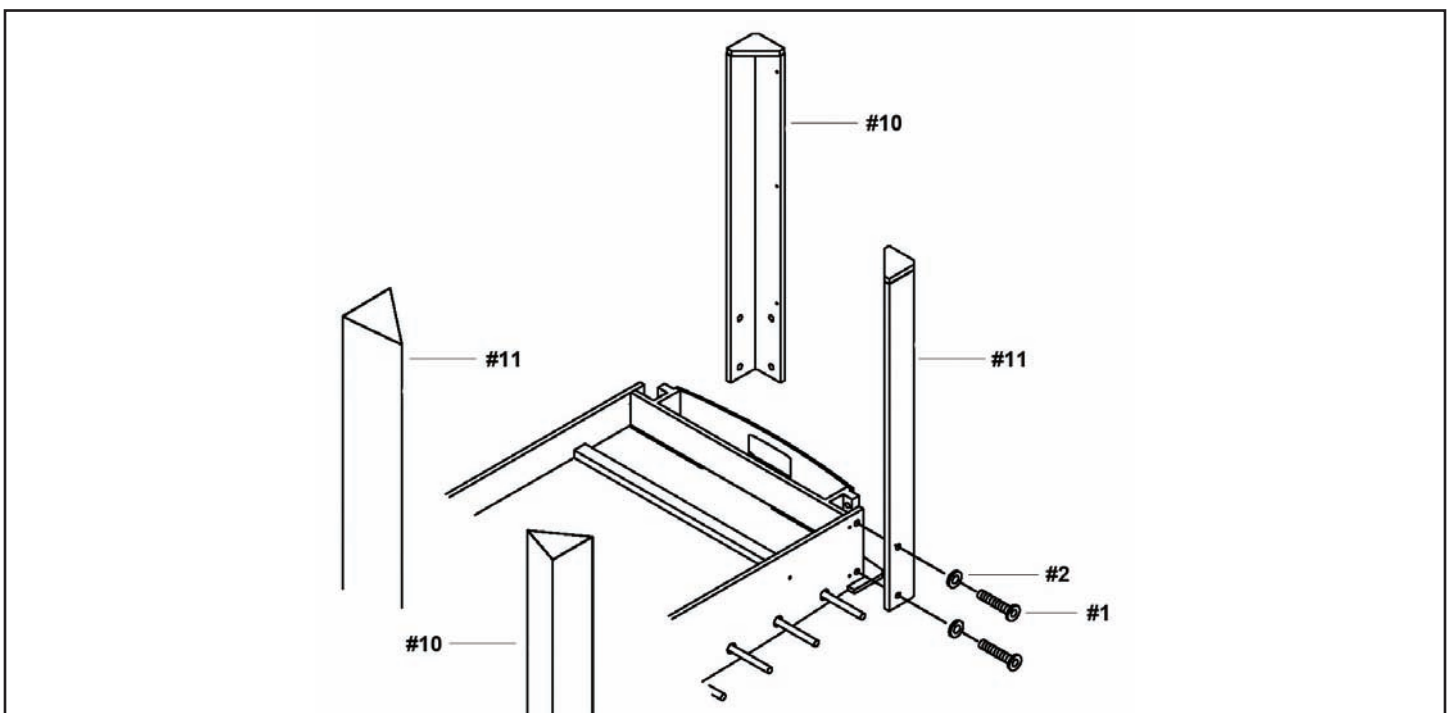



## ASSEMBLY INSTRUCTIONS (CONT.)

8. Attach each LEG PANEL #12 to LEGS with 1/2" SCREW #4. *Note: MLS graphics should face outward.* Carefully turn table over.

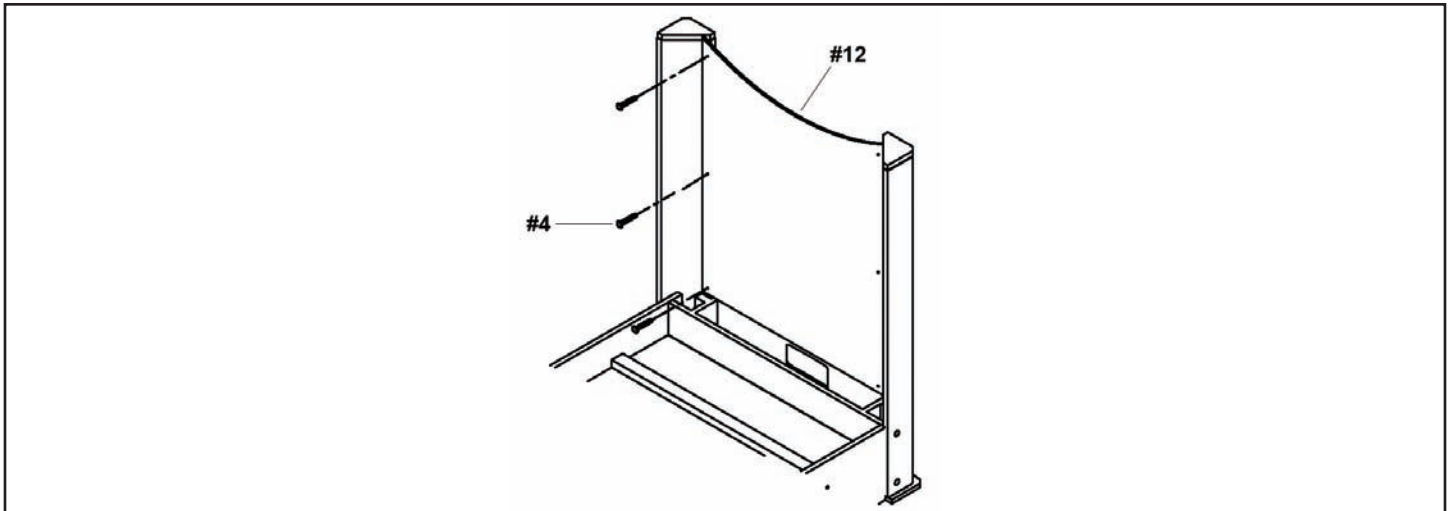

9. Attach HAND GRIP #13 to the marked end of each PLAYER ROD. Attach ROD END CAP #22 to the opposite end of PLAYER RODS.

10. Attach one MANUAL SCORER #24 to each end of the table with 1-1/2" FLAT SCREW #5.

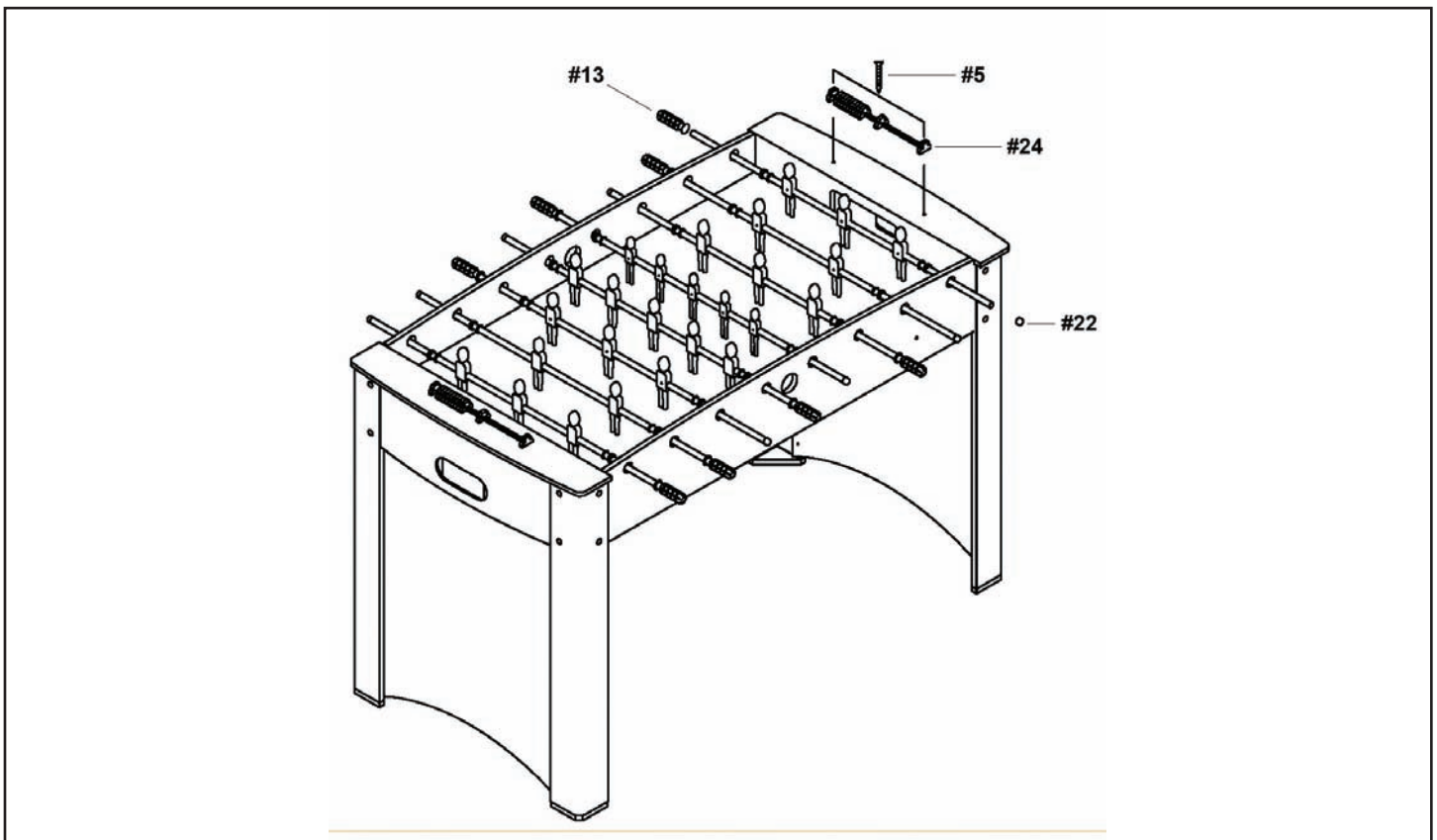

**CONGRATULATIONS!**



You have now assembled your MLS Soccer Table. Please note the Care and Use instructions below to ensure years of trouble free use of your game table.

## **CARE AND USE**

1. This product is intended for INDOOR use only.
2. Do NOT sit, climb or lean on the table.
3. Do NOT drag the table when moving it as this will damage the legs.