

# HARVIL 3-IN-1 FLIP TABLE ASSEMBLY INSTRUCTIONS

HARVIL®



NGD1018/1022

**THANK YOU!**

**HARVIL®**





















Thank you for your purchase of this Harvil product.

We work around the clock and around the globe to ensure that Harvil products maintain the highest possible quality. However, in the rare instance that your product is defective or missing parts, contact your retailer to submit parts requests or warranty claims. Please read the warranty information at the back of these assembly instructions for further details.

**IMPORTANT! PLEASE READ THESE ASSEMBLY INSTRUCTIONS IN ENTIRETY BEFORE ASSEMBLING YOUR PRODUCT.**

# PARTS IDENTIFIER (NOT TO SCALE)



<p>#1</p>  <p><b>TABLE BODY</b> 1 pc</p>	<p>#2</p>  <p><b>3/4" FLAT WASHER</b> 4 pcs</p>	<p>#3</p>  <p><b>3/4" HEX NUT</b> 2 pcs</p>	<p>#4</p>  <p><b>BOLT</b> 8 pcs</p>	<p>#5</p>  <p><b>5/16" FLAT WASHER</b> 8 pcs</p>
<p>#6</p>  <p><b>PUCK CATCHER</b> 2 pcs</p>	<p>#7</p>  <p><b>1/2" SCREW</b> 19 pcs</p>	<p>#8</p>  <p><b>1-1/2" FLATHEAD SCREW</b> 8 pcs</p>	<p>#9</p>  <p><b>TABLE TENNIS PADDLE</b> 2 pcs</p>	<p>#10</p>  <p><b>TABLE TENNIS TOP</b> 1 SET</p>
<p>#11</p>  <p><b>BARREL NUT</b> 8 pcs</p>	<p>#12</p>  <p><b>PEDESTAL PANEL</b> 2 pcs</p>	<p>#13</p>  <p><b>PEDESTAL BASE</b> 2 pcs</p>	<p>#14</p>  <p><b>TABLE TENNIS NET</b> 1 SET</p>	<p>#15</p>  <p><b>SIDE SUPPORT BRACE</b> 2 pcs</p>
<p>#16</p>  <p><b>STRIKER</b> 2 pcs</p>	<p>#17</p>  <p><b>STRIKER FELT</b> 2 pcs</p>	<p>#18</p>  <p><b>PUCK</b> 2 pcs</p>	<p>#19</p>  <p><b>BILLIARD BALLS</b> 1 SET</p>	<p>#20</p>  <p><b>TWO-PIECE CUE STICK</b> 2 pcs</p>
<p>#21</p>  <p><b>BRUSH</b> 1 pc</p>	<p>#22</p>  <p><b>TRIANGLE</b> 1 pc</p>	<p>#23</p>  <p><b>CHALK</b> 2 pcs</p>	<p>#24</p>  <p><b>TABLE LOCK</b> 4 pcs</p>	<p>#25</p>  <p><b>ACCESSORY RACK A</b> 1 pc</p>
<p>#26</p>  <p><b>ACCESSORY RACK B</b> 1 pc</p>	<p>#27</p>  <p><b>LEG LEVELER</b> 4 pcs</p>	<p>#28</p>  <p><b>WRENCH</b> 1 pc</p>	<p>#29</p>  <p><b>HEX WRENCH</b> 1 pc</p>	<p>#30</p>  <p><b>AIR HOCKEY PLAYFIELD</b> 1 pc</p>
<p>#31</p>  <p><b>LARGE BOLT</b> 2 pcs (PRE-INSTALLED)</p>	<p>#32</p>  <p><b>1-1/4" WASHER HEAD SCREW</b> 20 pcs (4PCS PRE-INSTALLED)</p>	<p>#33</p>  <p><b>TABLE TENNIS BALL</b> 2 pcs</p>	<p>#34</p>  <p><b>5/8" SCREW</b> 8 pcs</p>	<p>ADDITIONAL EQUIPMENT REQUIRED:</p>  <p><b>PHILLIPS HEAD SCREWDRIVER</b></p>

1. Find a clean, level surface to begin the assembly of your game table. The table will be partially assembled upside down and then turned over onto its legs. This is a heavy game and turning it over will require at least two strong adults.
2. Remove all of the contents from box and verify that you have all of the parts shown on the Parts Identifier before you begin assembly. **Note: Some parts may be pre-installed or pre-assembled.**
3. Some figures or drawings may not look exactly like your product. Please read and understand the text before beginning each assembly step.
4. When installing parts that have more than one screw or bolt, hand tighten all screws or bolts in place before finishing tightening with screwdriver or hex wrench.
5. Electric screwdrivers may be helpful during assembly; however, please set a low torque and use extreme caution because screws may be stripped or overtightened if the electric screwdriver's torque is set too high.

**WARNINGS!**

READ AND FOLLOW ALL ASSEMBLY, OPERATION AND SAFETY INSTRUCTIONS CAREFULLY.

CHOKER HAZARD - THIS TABLE CONTAINS SMALL BALLS AND PARTS - NOT  
SUITABLE FOR CHILDREN UNDER 3 YEARS OF AGE.

PINCH HAZARD – USE CAUTION WHEN ROTATING TABLE.

# ASSEMBLY INSTRUCTIONS

HARVIL®

1. Remove the four 1-1/4" WASHER HEAD SCREWS #32 from TABLE BODY #1 that secure the AIR HOCKEY PLAYFIELD #30 during shipping. **DO NOT DISCARD THESE SCREWS** -They will be used to re-attach the AIR HOCKEY PLAYFIELD. Remove and unpack accessory boxes from inside the TABLE BODY. Attach AIR HOCKEY PLAYFIELD #30 to the bottom of the TABLE BODY #1 with 1-1/4" WASHER HEAD SCREW #32. *Note: Feed power cord through the hole in the side of the TABLE BODY.*

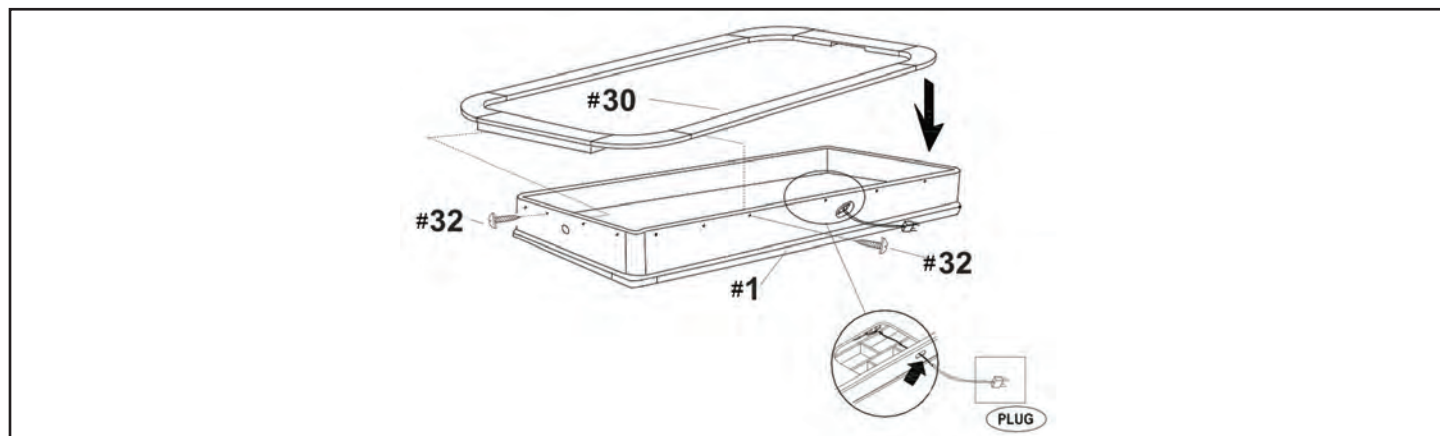

2. Attach one PEDESTAL PANEL #12 to each PEDESTAL BASE #13 as shown with 1-1/2" FLAT HEAD SCREW #8.

3. Thread two LEG LEVELERS #27 into the bottom of each PEDESTAL BASE.

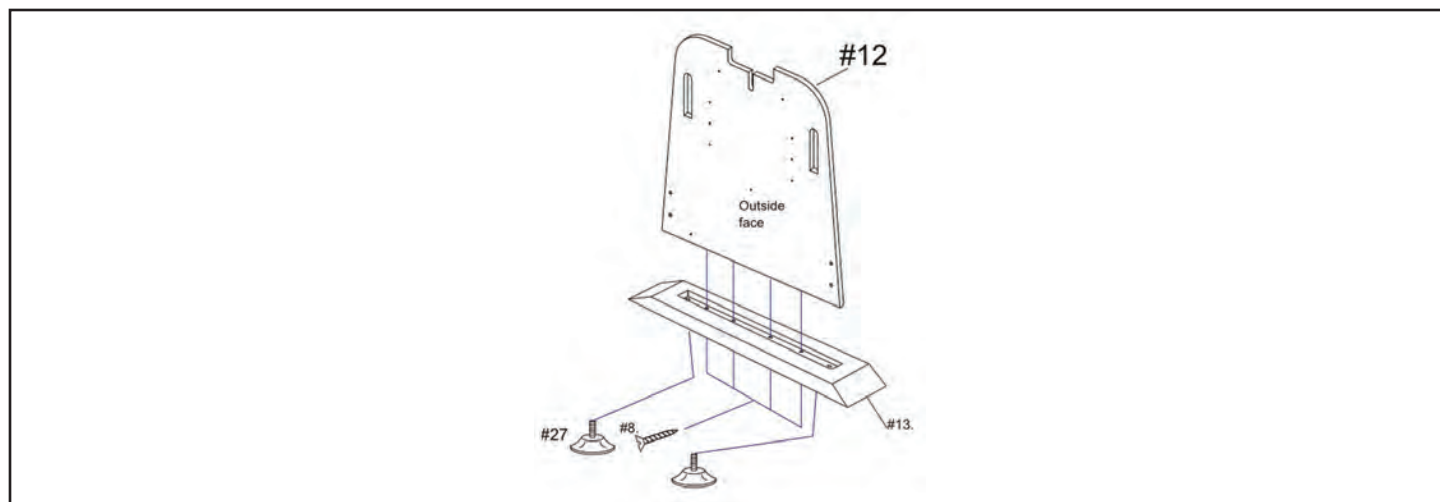

4. Attach two TABLE LOCKS #24 to each PEDESTAL PANEL with 5/8" SCREW #34.

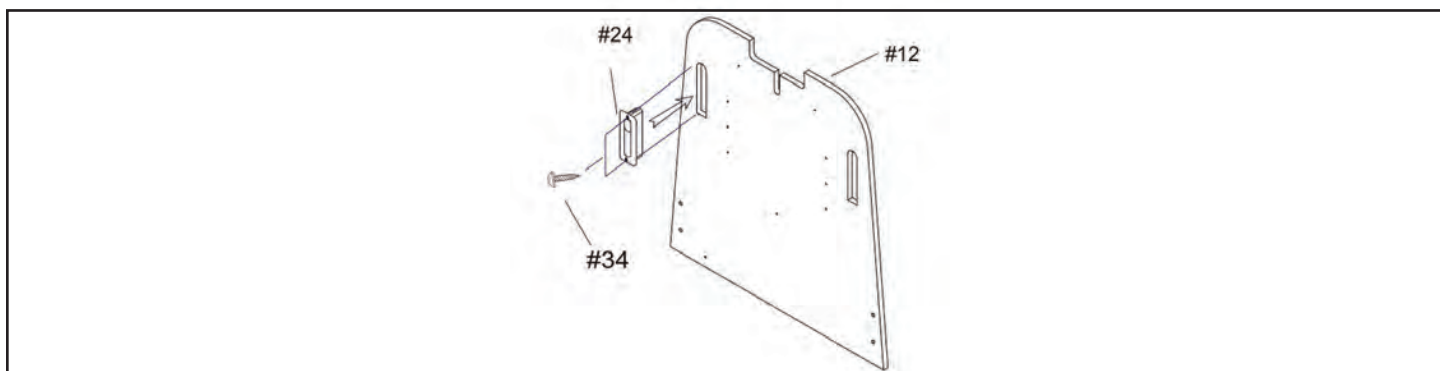

5. Insert four BARREL NUTS #11 into each SIDE SUPPORT BRACE #15 then attach SIDE SUPPORT BRACES to each PEDESTAL PANEL as shown with BOLT #4 and 5/16" FLAT WASHER #5.

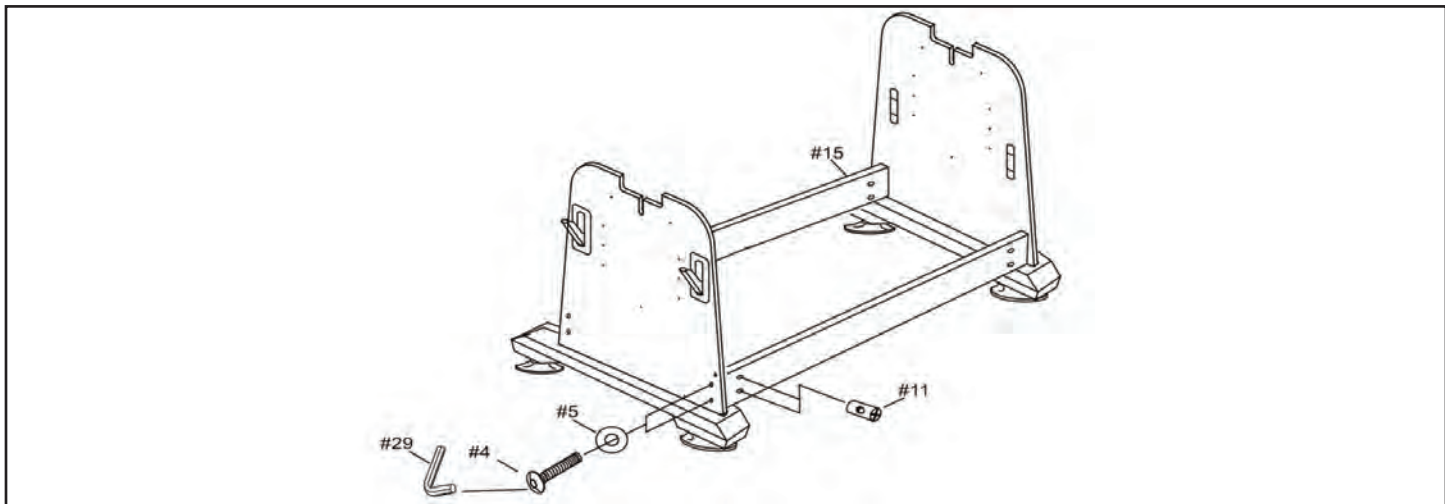

6. Pull each pre-installed LARGE BOLT #31 outward and tighten the attached nut. Slide one 3/4" FLAT WASHER #2 onto each LARGE BOLT #31. Carefully lift the assembled TABLE BODY and rest it in the center groove on the pedestal panels. Secure TABLE BODY with 3/4" FLAT WASHER #2 and 3/4" HEX NUT #3.

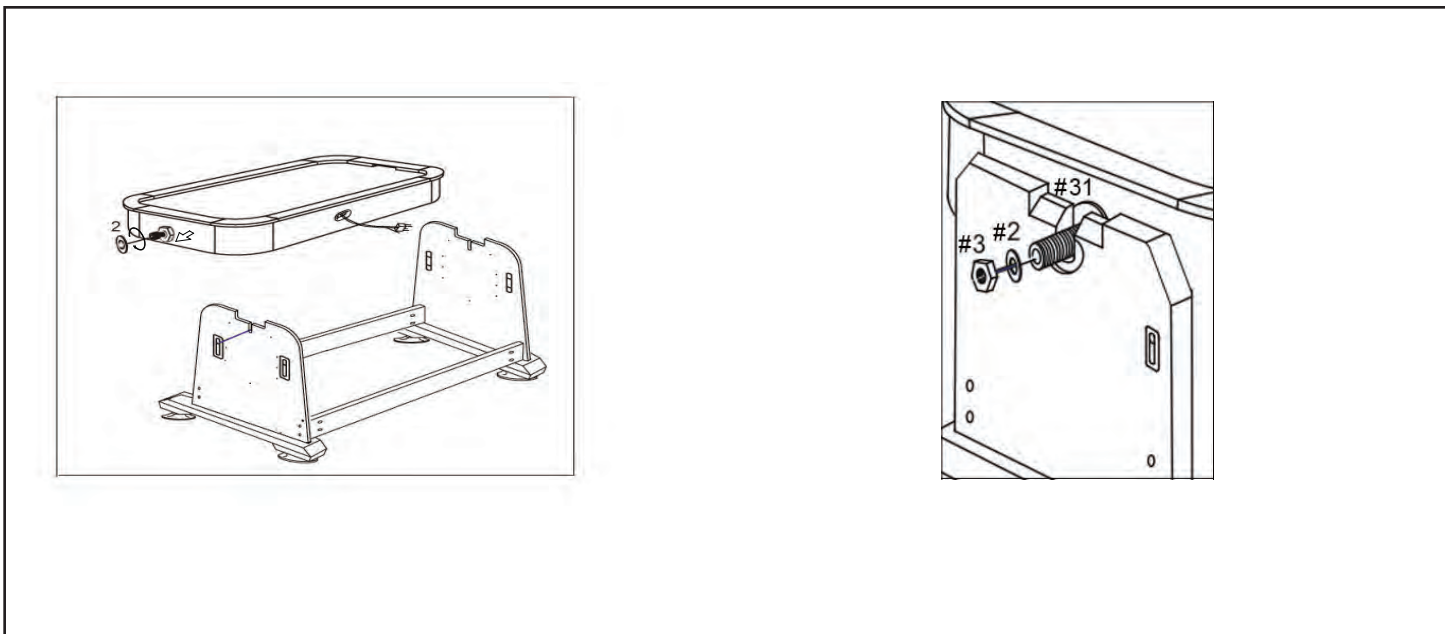

7. Attach one PUCK CATCHER #6 to each assembled PEDESTAL PANEL with 1/2" SCREW #7.
8. Attach ACCESSORY RACK B #26 to the PEDESTAL PANEL with corresponding pre-drilled holes using 1/2" SCREW #7.
9. Attach ACCESSORY RACK A #25 to the opposite PEDESTAL PANEL with 1/2" SCREW #7.

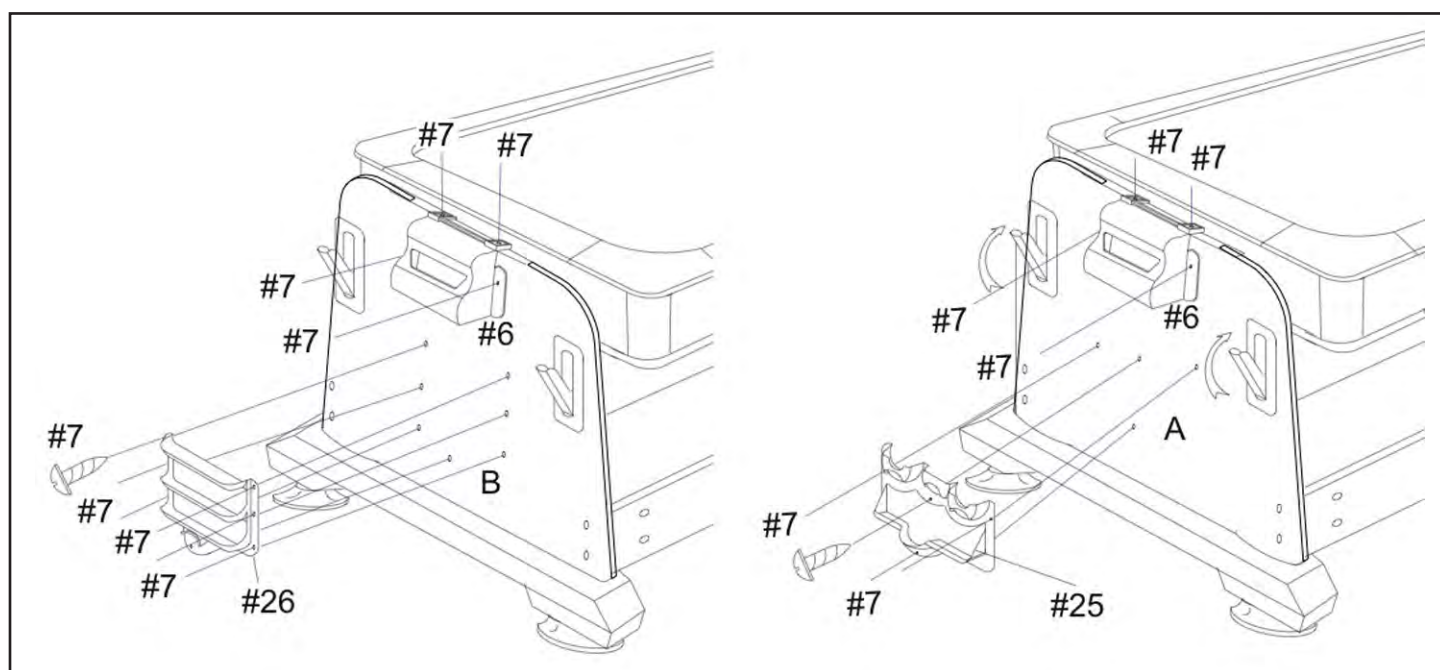

10. To assemble STRIKERS, remove paper backing from adhesive on STRIKER FELT #17. Adhere one STRIKER FELT to the bottom of each STRIKER #16.

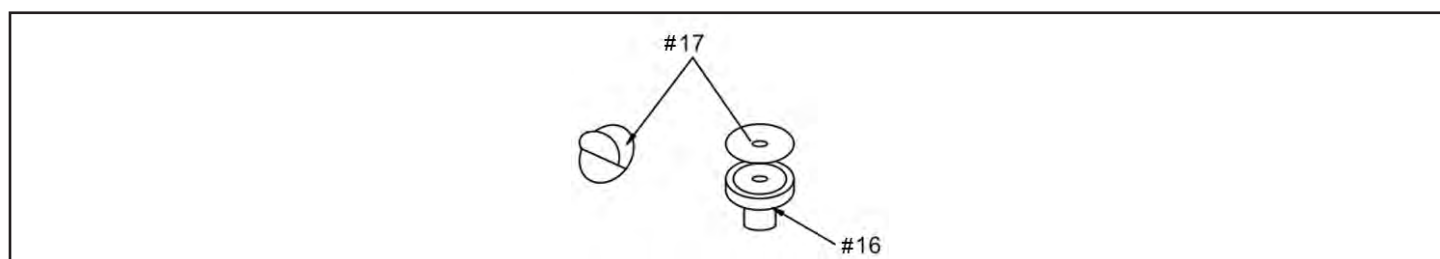

11. To assemble TABLE TENNIS TOP, place TABLE TENNIS TOP #10A and TABLE TENNIS TOP #10B on top of assembled table. Push halves together.

12. Clip each post of the TABLE TENNIS NET #14 to each side of the assembled TENNIS TABLE TOP at the center line. Attach the net to each post.

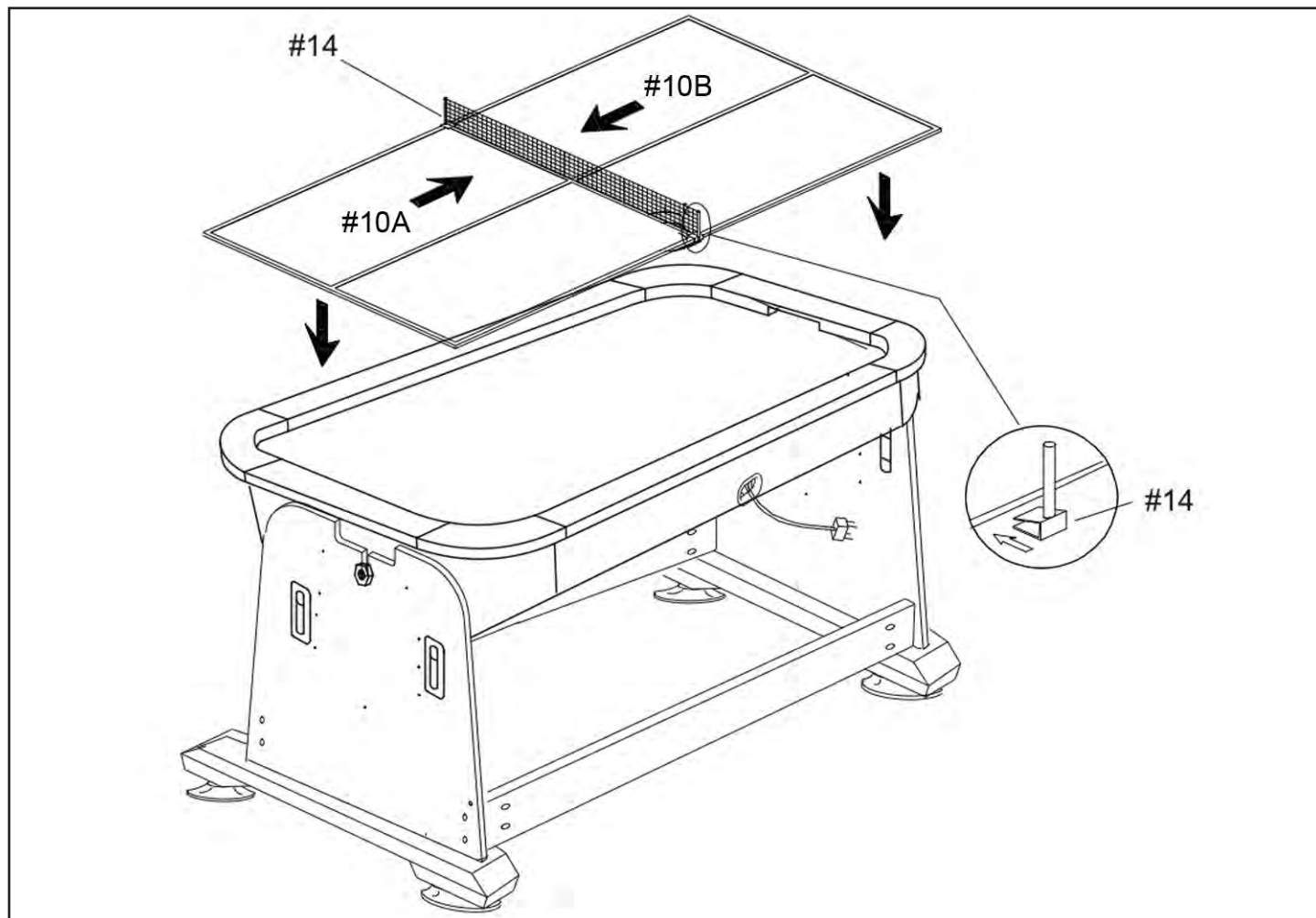



CONGRATULATIONS!

HARVIL®

You have now assembled your Harvil Game Table. Please note the Care and Use instructions below to ensure years of trouble free use of your game table.

### **CARE AND USE**

1. This product is intended for INDOOR use only.
2. Do NOT sit, climb or lean on the table.
3. Do NOT drag the table when moving it as this will damage the legs.

This Harvil product is warranted to the original purchaser to be free from defects in material or workmanship for a period of ninety days from the date of the original retail purchase.

This warranty does not cover defects or damage due to improper installation, alteration, accident or any other event beyond the control of the manufacturer. Defects or damage resulting from misuse, abuse or negligence will void this warranty. This warranty does not cover scratching or damage that may result from normal usage.

This product is not intended for institutional or commercial use; Harvil does not assume any liability for such use. Institutional or commercial use will void this warranty.

This warranty is nontransferable and is expressly limited to the repair or replacement of the defective product. During the warranty period, Harvil shall repair or replace defective parts at no cost to the purchaser. Shipping charges and insurance are not covered and are the responsibility of the purchaser. Labor charges and related expenses for removal, installation or replacement of the product or components are not covered under this warranty.

Harvil reserves the right to make substitutions to warranty claims if parts are unavailable or obsolete.

Harvil shall not be liable for loss of use of the product or other consequential or incidental costs, expenses or damages incurred by the consumer of any other use. The user assumes all risk of injury resulting from the use of this product.

This warranty is expressly in lieu of all other warranties, expressed or implied, including warranties of merchantability or fitness for use to the extent permitted by Federal or state law. Neither Harvil nor any of its representatives assumes any other liability in connection with this product.

**All warranty claims must be made through the retailer where the product was originally purchased. A purchase receipt or other proof of date of purchase will be required to process all warranty claims. The model number and part numbers found within the assembly instructions will be required when submitting any parts requests or warranty claims.**

**For further warranty information or inquiries, please call 800-759-0977**