

HARVIL TABLETOP POOL TABLE ASSEMBLY INSTRUCTIONS

HARVIL®



We work around the clock and around the globe to ensure that Harvil products maintain the highest possible quality. However, in the rare instance that your product is defective or missing parts, **PLEASE DO NOT RETURN IT TO THE STORE.** Contact us through one of the following methods:

Manufacturer

Harvil ®

6700 Fallbrook Ave Ste 203A

West Hills, CA 91307

USA

Phone: 866-507-3861

Fax: 866-507-3862







www.harvil.com

Please have your model number and part number available for Customer Service Representatives prior to calling. These numbers are available in these assembly instructions.

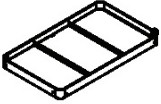
IMPORTANT! PLEASE READ THESE ASSEMBLY INSTRUCTIONS IN ENTIRETY BEFORE ASSEMBLING YOUR PRODUCT.

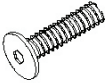
PARTS IDENTIFIER (NOT TO SCALE)

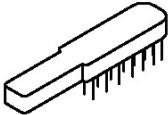
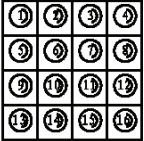

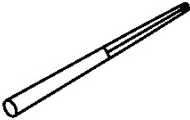
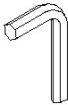
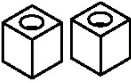
#1  TABLE BODY 1 pc	#2  LEG 4 pcs	#3  BOLT 8 pcs	#4  FLAT WASHER 8 pcs	#5  BRUSH 1 pc
#6  BILLIARD BALLS 1 SET	#7  TRIANGLE 1 pc	#8  CUE STICK 2 pcs	#9  HEX WRENCH 1 pc	#10  CHALK 2 pcs

ADDITIONAL EQUIPMENT REQUIRED:



1. Find a clean, level surface to begin the assembly of your game table. The table will be partially assembled upside down and then turned over onto its legs.
2. Remove all of the contents from box and verify that you have all of the parts shown on the Parts Identifier before you begin assembly. **Note: Some parts may be pre-installed or pre-assembled.**
3. Some figures or drawings may not look exactly like your product. Please read and understand the text before beginning each assembly step.
4. When installing parts that have more than one screw or bolt, hand tighten all screws or bolts in place before finishing tightening with screwdriver or hex wrench.
5. Electric screwdrivers may be helpful during assembly; however, please set a low torque and use extreme caution because screws may be stripped or overtightened if the electric screwdriver's torque is set too high.

WARNINGS!

READ AND FOLLOW ALL ASSEMBLY, OPERATION AND SAFETY INSTRUCTIONS CAREFULLY.

CHOKER HAZARD - THIS TABLE CONTAINS SMALL BALLS AND PARTS - NOT SUITABLE FOR CHILDREN UNDER 3 YEARS OF AGE.

1. Attach one LEG #2 to each corner of the TABLE BODY #1 with BOLT #3 and FLAT WASHER #4. *Note: The table is assembled upside down.*

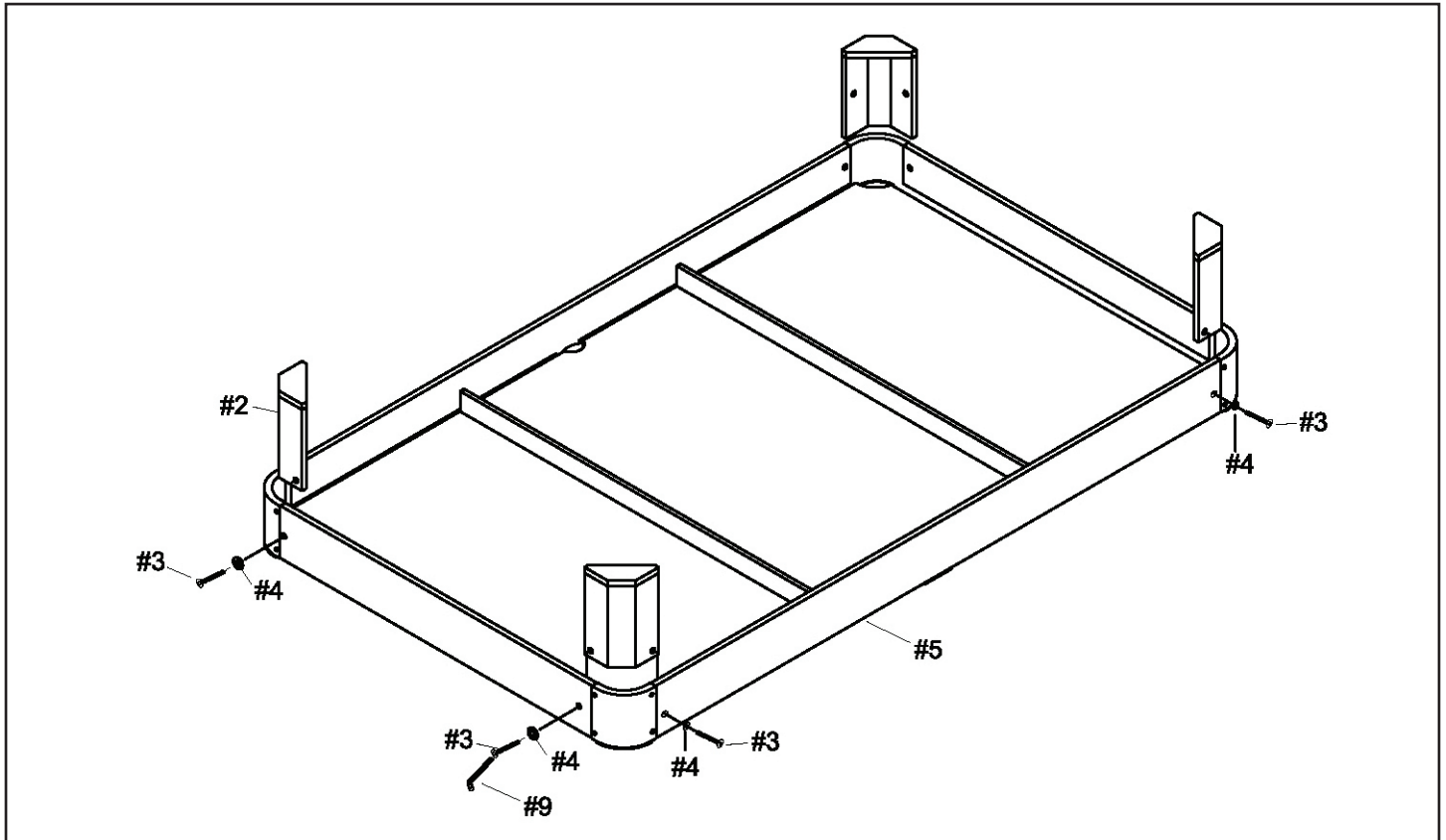

Congratulations!

You have now assembled your Harvil Game Table. Please note the Care and Use instructions below to ensure years of trouble free use of your game table.

CARE AND USE

1. This product is intended for INDOOR use only.
2. Do NOT sit, climb or lean on the table.
3. Do NOT drag the table when moving it as this will damage the legs.

90 DAY LIMITED WARRANTY

HARVIL®

This consumer warranty extends to the original consumer purchase of any HARVIL Product (hereinafter referred to as the "Product").

WARRANTY DURATION: This Product is warranted to the original consumer purchase of a period of 90 days from the original purchase.

WARRANTY PERFORMANCE: During the 90 day warranty period, HARVIL shall repair, or replace with a comparable model, the Product, or component thereof, which may prove defective under normal use and proper care, and which our examination shall disclose to our satisfaction to be thus defective.

A purchase receipt or other proof of date of purchase will be required before warranty service is performed.

Harvil®

Attn: Warranty Dept
6700 Fallbrook Ave Ste 203A
West Hills, CA 91307
USA

Phone: 866-507-3861
Fax: 866-507-3862
Email: info@harvil.com

Other than shipping requirements no charge will be made for such repair or replacement of in-warranty Products. HARVIL strongly recommends that the Product is insured for value prior to shipping/mailing.

WARRANTY DISCLAIMERS: ANY IMPLIED WARRANTIES ARISING OUT OF THIS SALE, INCLUDING BUT NOT LIMITED TO THE IMPLIED WARRANTIES OF MERCHANTABILITY AND FITNESS FOR A PARTICULAR PURPOSE, ARE LIMITED IN DURATION TO THE ABOVE 90 DAY PERIOD. HARVIL SHALL NOT BE LIABLE FOR LOSS OF USE OF THE PRODUCT OR OTHER CONSEQUENTIAL OR INCIDENTAL COSTS, EXPENSES OR DAMAGES INCURRED BY THE CONSUMER OF ANY OTHER USE.

Some states do not allow the exclusion or limitation of implied warranties or consequential or incidental damages, so the above limitations or exclusions may not apply to you.

LEGAL REMEDIES: This warranty gives you specific legal rights and you may have other rights which may vary from state to state